

Rudder Bushings

DX490



DX490 Rudder Bushings are molded from a 70 Scale D, Durometer, Nitrile Rubber Compound, formulated to withstand the rugged "impact" service encountered in ship's rudder steering systems. They possess high rigidity for maximum dimensional stability while still retaining a degree of resiliency required to dampen peak shock loads.

DX490 Rudder Bushings are homogenous cylinders molded with longitudinal lubrication grooves. Grease, oil and water serve equally well as lubricants. The DX490 Rudder Bushing is resistant to deterioration by hydrocarbons, acids, salt water corrosion and electrolysis.

CAUTION:

DX490 Rudder Bushings are supplied with molded I.D. and O.D. dimensions which allow ample material for finish machining. However, when finish boring I.D. dimensions do not remove more than 70% of the lubricant groove depth.

IMPORTANT: In addition to interference press fit, DX490 Rudder Bushings must be mechanically secured with set screws or other locking devices to prevent movement during operation and the expected operating temperature range.

FIGURE 13

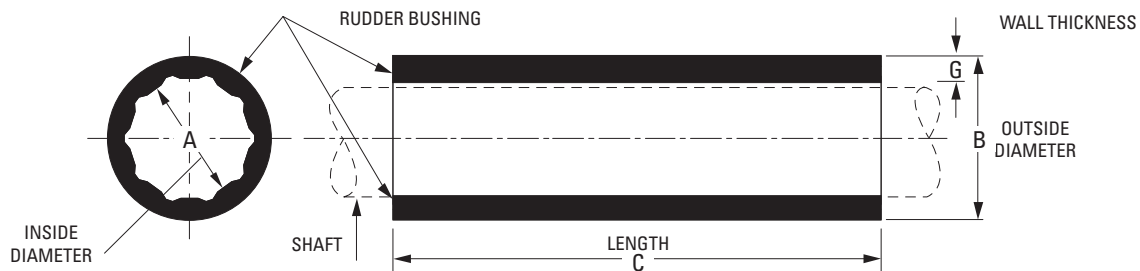

Part Number	Code	A		B		C		G		Gross Wt.	
		Shaft Diameter inches	mm	Outside Diameter inches	mm	Length inches	mm	Metal Thickness inches	mm	lb.	kg.
812100038	DX150	1.45	36.83	2.35	59.69	11	279.40	1.62	41.15	1.0	0.5
812100044	DX175	1.70	43.18	2.59	65.79	13	330.20	1.97	50.04	1.5	0.7
812100051	DX200	1.95	49.53	3.07	77.98	15	381.00	2.20	55.88	2.5	1.1
812100057	DX225	2.18	55.37	3.32	84.33	7 1/2	190.50	2.57	65.28	2.3	1.0
812100064	DX250	2.44	61.98	3.68	93.47	9	228.60	2.75	69.85	2.7	1.2
812100070	DX275	2.70	68.58	3.92	99.57	10	254.00	2.97	75.44	3.0	1.4
812100076	DX300	2.95	74.93	4.20	106.68	11	279.40	3.39	86.11	4.0	1.8
812100083	DX325	3.19	81.03	4.42	112.27	12	304.80	3.60	91.44	4.0	1.8
812100089	DX350	3.34	84.84	5.19	131.83	13	330.20	3.76	95.50	7.5	3.4
812100095	DX375	3.66	92.96	5.18	131.57	14	355.60	4.05	102.87	6.5	2.9
812100102	DX400	3.93	99.82	5.45	138.43	15	381.00	4.28	108.71	7.5	3.4
812100108	DX425	4.16	105.66	5.68	144.27	16	406.40	4.55	115.57	9.0	4.1
812100114	DX450	4.42	112.27	6.02	152.91	17	431.80	4.68	118.87	11.0	5.0
812100121	DX475	4.65	118.11	6.01	152.65	18	457.20	5.05	128.27	10.0	4.5
812100127	DX500	4.93	125.22	6.68	169.67	19	482.60	5.31	134.87	15.0	6.8
812100135	DX525	5.15	130.81	6.90	175.26	20 1/2	520.70	5.64	143.26	17.0	7.7
812100140	DX550	5.39	136.91	7.61	193.29	21	533.40	5.91	150.11	21.0	9.5
812100146	DX575	5.65	143.51	7.65	194.31	22	558.80	6.00	152.40	22.0	10.0
812100152	DX600	5.87	149.10	8.65	219.71	22	558.80	6.40	162.56	24.0	10.9
812100165	DX650	6.36	161.54	8.67	220.22	22	558.80	6.84	173.74	27.8	12.6
812100171	DX675	6.65	169.91	9.00	228.60	23	584.20	7.16	181.86	31.0	14.1
812100178	DX700	6.88	174.75	9.08	230.63	24 1/2	622.30	7.35	186.69	31.0	14.1
812100184	DX725	7.10	180.34	10.47	265.94	27 1/2	698.50	7.60	193.04	38.0	17.2
812100191	DX750	7.33	186.18	10.47	265.94	27 1/2	698.50	8.07	204.98	35.0	15.9
812100197	DX775	7.70	195.58	10.47	265.94	27 1/2	698.50	8.30	210.82	45.0	20.4
812100203	DX800	7.82	198.63	10.56	268.22	29 1/2	749.30	8.50	215.90	50.0	22.7
812100216	DX850	8.37	212.60	12.20	309.88	35	889.00	9.09	230.89	65.0	29.5
812100222	DX875	8.64	219.46	11.32	287.53	32 1/2	825.50	9.11	231.39	58.0	26.3
812100229	DX900	8.89	225.81	11.32	287.53	32 1/2	825.50	9.49	241.05	73.0	33.1
812100235	DX925	9.11	231.39	12.22	310.39	35	889.00	9.72	246.89	85.0	38.6

DX490 NON-METALLIC BUSHINGS

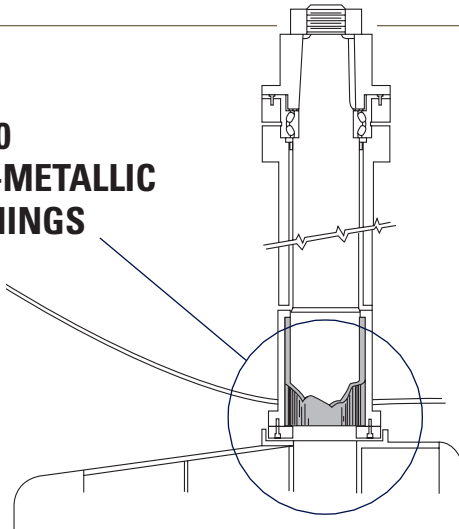

PHYSICAL PROPERTIES:

Deformation	Load PSI	Deflection	Temperature	
	225	.004"	72° F	
	300	.0045"	72° F	
Compressive Strength	15,000	Elastic Limit	72° F	
Tensile	3000 PSI			
Expansion and Contraction	Configuration	Contraction	Temp.	Recovery
	Std. Tubular	.002" -.0025" per inch of OD	-20° F	100%
Absorption	Aging	Liquid	Temp.	Vol. Change %
	70 hrs.	ASTM #3 Oil	212° F	+ 4.9%
	70 hrs.	ASTM #3 Oil	100° F	+ less than 1%
	70 hrs.	ASTM #3 Oil	72° F	Negligible
	70 hrs.	H ₂ O	212° F	+ 2.6%
	70 hrs.	H ₂ O	100° F	Negligible
Range of working temperature - -20° to 180° continuous service.				

CALCULATING THE FINISHED (MACHINED) SIZE OF DX490

Nominal Bushing I.D. and O.D. dimensions must be adjusted to allow for proper shaft to bearing running clearance, thermal expansion and contraction and interference press fit. Before machining, calculate the finished machined bearing I.D. and O.D. dimensions as follows:

EXAMPLE:

Nominal Shaft Diameter: 8 inches
Nominal Bearing Housing Diameter: 12 inches

To determine the finished machined bearing I.D. dimension

refer to the machining tables and add the running clearance (Table X), thermal factor (Table Y) and press fit allowance (Table Z), to the nominal shaft diameter.

Finished Machined Bearing I.D. Dimension equals:

+ Nominal Bearing Shaft Diameter	8.000
+ Running Clearance (Table X)	0.018
+ Thermal Factor (Table Y)	0.016
+ Press Fit Allowance (Table Z)	0.008
	8.042 inches I.D.

To determine the finished machined bearing O.D. dimension

Refer to the machining tables and add the thermal factor (Table Y) and the press fit allowance (Table Z), to the nominal bearing housing diameter.

Finished Machined Bearing O.D. Dimension equals:

+ Nominal Bearing Housing Diameter	12.000
+ Thermal Factor (Table Y)	0.016
+ Press Fit Allowance (Table Z)	0.008
	12.024 inches O.D.

TABLE X — RUNNING CLEARANCE

Nominal ID inches	2	3	4	5	6	7	8	9	10	11	12	13	14
Allowance inches	0.012	0.013	0.014	0.015	0.016	0.017	0.018	0.019	0.020	0.021	0.022	0.023	0.024
Nominal ID mm	50.80	76.20	101.60	127.00	152.40	177.80	203.20	228.60	254.00	279.40	304.80	330.20	355.60
Allowance mm	0.30	0.33	0.36	0.38	0.41	0.43	0.46	0.48	0.51	0.53	0.56	0.58	0.61

TABLE Y — THERMAL FACTOR

Nominal ID inches	2	3	4	5	6	7	8	9	10	11	12	13	14
Allowance inches	0.004	0.006	0.008	0.010	0.012	0.014	0.016	0.018	0.020	0.022	0.024	0.026	0.028
Nominal ID mm	50.80	76.20	101.60	127.00	152.00	177.80	203.20	228.60	254.00	279.40	304.80	330.20	355.60
Allowance mm	0.10	0.15	0.20	0.25	0.30	0.35	0.41	0.46	0.51	0.56	0.61	0.66	0.71

TABLE Z — PRESS FIT ALLOWANCE

Nominal ID inches	2	3	4	5	6	7	8	9	10	11	12	13	14
Allowance inches	0.005	0.005	0.005	0.005	0.005	0.008	0.008	0.008	0.008	0.010	0.010	0.010	0.010
Nominal ID mm	50.80	76.20	101.60	127.00	152.00	177.80	203.20	228.60	254.00	279.40	304.80	330.20	355.60
Allowance mm	0.13	0.13	0.13	0.13	0.13	0.20	0.20	0.20	0.20	0.25	0.25	0.25	0.25