

# COMMERCIAL STUFFING BOXES

## AIR SEAL RING REPLACEMENT INSTRUCTIONS

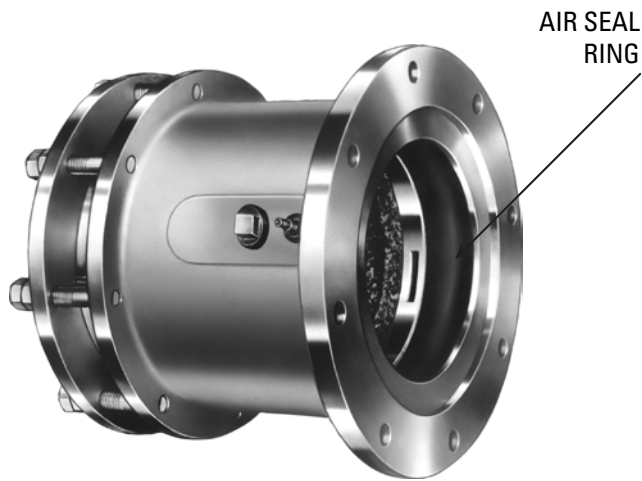

**FIGURE A.**

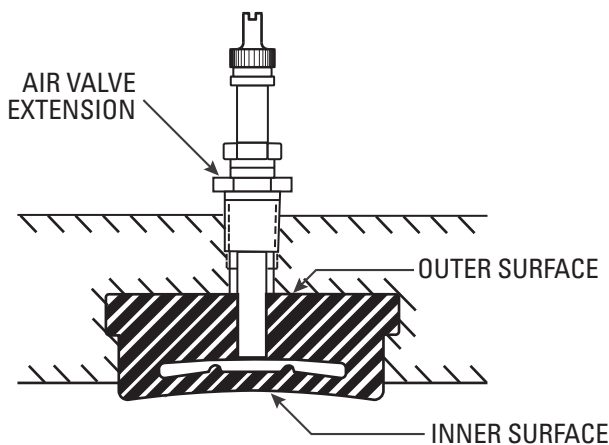

**FIGURE B.**

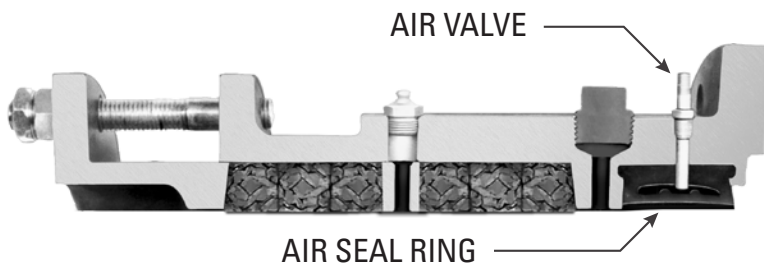

**FIGURE C.**

1. Remove stuffing box assembly from shaft.
2. Remove air valve extension from stuffing box housing.
3. Use a screw driver to pry out old air seal ring.
4. Coat new air seal ring with mild soap solution for lubrication.
5. Using a blunt object, force the ears of the replacement air seal ring into the machined grooves of the air seal ring slot.
6. Screw 1/4" NPT drill jig fitting, supplied in repair kit, into air valve hole on stuffing box housing.
7. Drill through the air valve hole into the rubber air seal ring using a 13/64" (5.159mm) diameter drill.

**CAUTION! Take care that the drill penetrates only the outer surface of the air seal ring into the air cavity, but not into or through the inner surface. The drill can be felt with a finger on the air seal inner surface when it has penetrated the outer surface. (See Figure B)**

8. Remove drill jig fitting.
9. Install the air valve extension.
10. Place a cylindrical object the same diameter as the shaft journal into the stuffing box and inflate the air seal ring to a test pressure of 80 P.S.I. The air seal ring should hold air pressure for 24 hours.

NOTE: When replacing packing ring an adequate seal should be obtained with about 15 P.S.I.G. air pressure.