

DURAMAX® Ultra-X®

HIGH PERFORMANCE MARINE PACKING

INSTALLATION INSTRUCTIONS

The following steps are important for maximum service life.

1. PREPARATION: Remove old packing from stuffing box. Clean box and shaft thoroughly. Examine shaft or sleeve for wear or scoring. Replace if wear is excessive.

2. IMPORTANT: MAKE SURE PACKING IS THE PROPER SIZE. To determine correct size, first measure the diameter of the shaft (at position where packing will operate). Then measure the internal diameter of the stuffing box (for the OD of the ring). Subtract the ID measurement from the OD measurement and divide by 2. The result is the required size. Ultra-X Packing is available in any size from 1/4" to 1-1/2".

3. ALWAYS CUT THE PACKING INTO SEPARATE RINGS. Never wind packing into stuffing box. Rings can be cut with butt (square) or skive (diagonal) joints. **IMPORTANT: IF POSSIBLE CUT EACH RING ON A MANDREL**, with the same diameter of the shaft in the stuffing box area, to keep proper joint angle. Note: If there is no shaft wear, rings can be cut using the shaft outside the stuffing box. Rings should be cut to correct size - or service life could be reduced. When cutting rings, hold packing tightly on the mandrel, but don't stretch packing excessively. Ultra-X can easily be cut with a sharp utility knife.

4. INSTALL ONE RING AT A TIME. Make sure packing is clean of any dirt from handling. Joints of successive rings should be staggered - at least 90 degrees apart. Each ring should be seated firmly using tamping tool. When the packing rings can be reached by the nose of the gland, tamping should be supplemented by the gland.

5. BREAK-IN PROCEDURE IS CRITICAL TO INSURE LONG PACKING LIFE. After the last ring is installed, take up bolts finger tight. Do not jam the packing into place by excessive gland loading. Make sure gland bolts are taken up evenly. Stopping leakage at this point will cause the packing to burn up. For proper break-in Ultra-X must be packed loosely for the first 5-10 hours of operation.

6. AFTER THE INITIAL BREAK-IN PERIOD THE GLAND MAY BE TIGHTENED TO THE DESIRED LEAKAGE.

Operation NOTE: Because of the superior thermal conductivity of Ultra-X, the stuffing box may run hotter when compared to traditional flax packing. This is normal. Ultra-X packing minimizes shaft wear and scoring by transferring frictional heat to the stuffing box which acts as a heat sink. Flax packing acts as an insulator keeping harmful heat on the shaft.

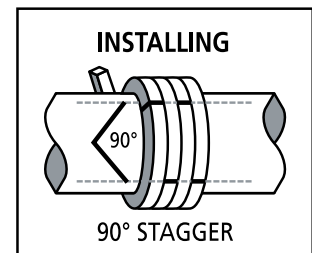
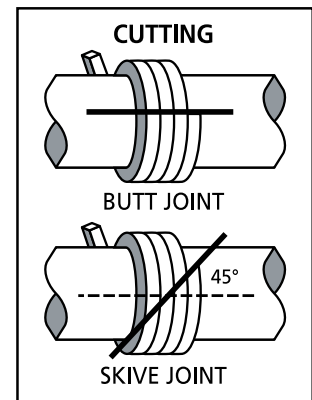

Duramax® Ultra-X® is designed for use in any marine stuffing box.

Duramax Ultra-X will assure you the highest performance of any braided marine packing on the market today - whether it's in a Johnson® Heavy-Duty Stuffing Box or any other marine stuffing box.

Unmatched high performance in both salt water or fresh water environments.

Ultra-X is engineered to operate in all marine environments. Its unique imbedded construction eliminates the potential for galvanic corrosion making it safe for any marine application.

©2019 Duramax Marine®
17990 Great Lakes Parkway, Hiram, Ohio 44234 U.S.A.
info@DuramaxMarine.com

Duramax Marine® is an ISO 9001:2015 Certified Company

DURAMAX MARINE®

Products And Knowledge You Trust

p: 440.834.5400 f: 800.497.9283

www.DuramaxMarine.com

DM-1065.117 ULTRAXI 09-20-19